



**Thin-Cake Filtration Technologies for Removing
Activated Carbon, Catalysts and Other Trace Solids
From Active Pharmaceutical Ingredient (API) Slurries**

The BHS technologies of Vertical Candle Filters and Horizontal Pressure Plate Filters provide improved product quality with more efficient operations compared with manual pressure filters. The different technologies allow for the selection of the optimum process solution depending upon the cake characteristics and cake structure. Fully automatic operations provide for complete containment of the solids and liquids for reduced maintenance costs and overall project savings.

**By
Barry A. Perlmutter
President and Managing Director**



INTRODUCTION

As the pharmaceutical industry has changed and grown since the mid-1980's, there are increasing concerns about the safe handling of active pharmaceutical ingredients (APIs). To meet lower exposure limits of unknown compounds and to have batch-to-batch integrity with less operator interaction, the industry's need for new technologies has expanded.

One area of importance is now the efficient removal of activated carbon, metal catalysts and trace insolubles, such as diatomaceous earth, from API slurries. Currently, most API slurries are clarified with the use of manual plate filters, filter presses, bag filters, cartridge filters and other conventional filter equipment. All of these units require manual operations for cake discharge and cleaning between batches or campaigns as well as suffer from high labor and maintenance costs, high disposal costs and the exposure of the operators and the environment to toxic and hazardous solvents and solids as well as to used and contaminated filter cloth, bag filters and filter cartridges.

This article discusses the use of thin-cake vertical candle filters and horizontal pressure plate filters as alternatives to manual and conventional filter equipment. These new technologies are described as well as the selection process. The article includes test data and case histories and concludes with a discussion of clean-in-place operations and current Good Manufacturing Practices (cGMP) guidelines. ANSI/ISA S88 (and IEC 61512-1 in the international arena) batch process control system standards are also examined for validation. Finally, factory and site acceptance testing is described.

CLARIFICATION OF SLURRIES & RECOVERY OF SOLIDS

Candle Filters and Pressure Plate Filters are installed for clarification and recovery applications from liquids with low solids content. The candle filters are vertical candles while the pressure plate filters are horizontal plates. The cake structure as well as the process parameters determines the optimum thin-cake technology.

Description and Operation of the Candle Filter

The BHS Candle Filter provides for thin-cake pressure filtration, cake washing, drying, reslurry and automatic discharge as well as heel filtration in an enclosed, pressure vessel. Units are available from 0.17 m² up to 100m² of filter area per vessel.

Filter Candles & Media

The filter candles, as shown in Figure 1, consist of three components: single-piece dip pipe for filtrates and gas, perforated core with outer support tie rods and filter sock media. The filtrate pipe is the full length of the candle and ensures high liquid flow as well as maximum distribution of the gas during cake discharge. The perforated core can be a synthetic material, stainless steel or Hastelloy and is designed for the full pressure of the vessel. The outer support tie rods provide for an annular space between the media and the core for a low pressure drop operation and efficient gas expansion of the filter media sock for cake discharge. Finally, the filter media is a synthetic type with a clean removal efficiency to less than 1-3 microns. As the cake builds up, removal efficiencies improve to less than 1 micron.

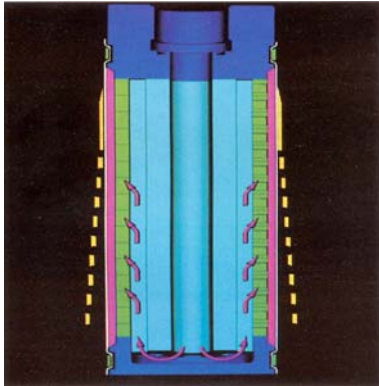

Figure 1: BHS Candle Showing Gas Flow to Expand the Filter Media Sock for Cake Discharge

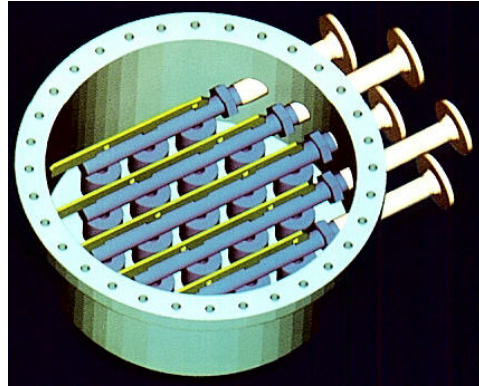

Figure 2: BHS Candle Filter

Filter Vessel & Candle Registers

The candle filter vessel is constructed of stainless steel, Hastelloy, other metals or carbon steel lined. Within the vessel are candle registers (horizontal manifolds). Each candle is connected to a register with a positive seal to prevent bypass. Each register may contain from 1-20 candles depending upon the filter size. The registers convey the liquid filtrate as well as the pressure gas for filter media sock expansion. Each register is controlled with automated valves to ensure optimum flow in both directions. Figure 2 illustrates the candle filter vessel.

Automatic Process Cycles

Filling: The slurry feed enters the bottom of the filter vessel.

Filtration: The slurry is pumped under pressure into the vessel. Cake will deposit on the outside of the candle; the separated filtrate will flow through the filtrate pipe and the registers. This process continues until one of the following conditions is achieved: maximum pressure drop, maximum cake thickness, minimum flow or time.

Washing: Displacement washing or recirculation washing.

Drying: Blowing gas, steam or “shock” drying.

Heel (Falling-Film) Filtration: The liquid remaining in the vessel cone after filtration or washing is completely filtered.

Cake Discharge: Gas flows through the candle register and down each of the filtrate pipes. The filter media sock gently expands allowing for cake discharge, as shown in Figure 1. Alternatively, the cake can be discharged as a slurry.

Description and Operation of the Pressure Plate Filter

The pressure plate filter has similar operating characteristics to the candle filter. The filter design is shown in Figure 3.

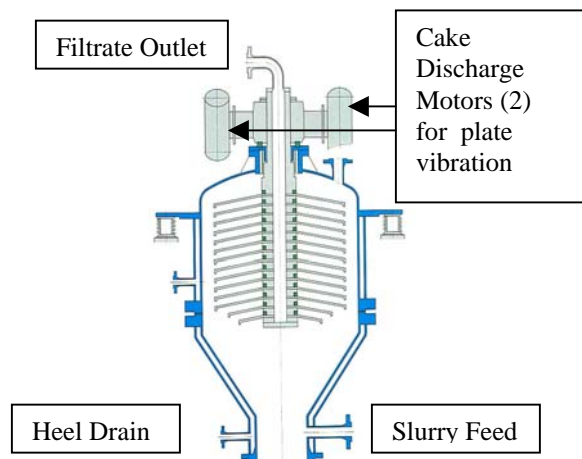

Figure 3: BHS Pressure Plate Filter

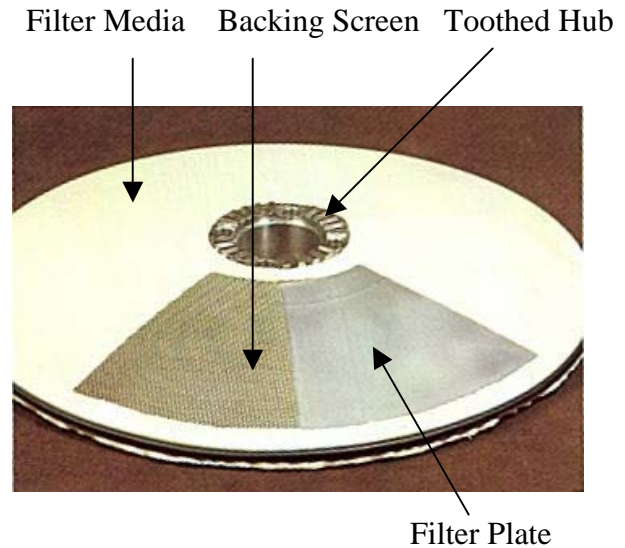

Figure 4: Filter Plate

Automatic Process Cycles

Filling: The slurry feed enters the bottom of the filter vessel.

Filtration: The slurry is pumped under pressure into the vessel. Cake will deposit on the top of the plates. The separated filtrate will flow through the plates to the center main filtrate outlet. This process continues until one of the following conditions is achieved: maximum pressure drop, maximum cake thickness, minimum flow or time.

Washing: Displacement washing or recirculation washing.

Drying: Blowing gas, steam or “shock” drying.

Heel Filtration: The liquid remaining in the vessel cone after filtration or washing is completely filtered.

Cake Discharge: As shown in Figure 5, the motors on the top of the filter operate at different frequencies and the plates gently vibrate for cake discharge. The plates vibrate in the vertical and horizontal planes and the solids are conveyed in an elliptical pattern to the outside of the vessel. Gas assist helps in the discharge process. There are no rotating plates, gears or bushings and mechanical seals are not required.

Description and Operation of the Pressure Plate Filter (Continued)

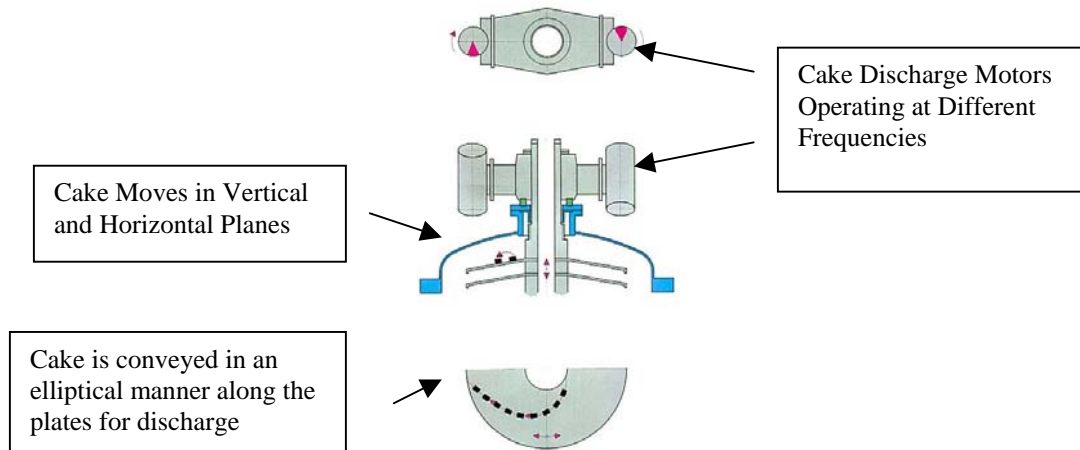

Figure 5: Cake Discharge in the Pressure Plate Filter

SELECTION OF CANDLE VERSUS PRESSURE PLATE FILTER TECHNOLOGIES

The major difference between the two units depends on the cake structure that is formed. Some cakes are better handled in the horizontal and some in the vertical.

Cake Thickness and Filtration: The candle filter is limited to cake structures that can be formed to about 5 – 20 mm. The pressure plate filter can handle cakes up to 65 mm. Both units can conduct filtration up to 150 psig.

Filter Media: The candle filter uses only synthetic media with a clean removal efficiency from 1 –3 micron range and higher. The pressure plate filter can also use metal media. For the pressure plate filter, the clean micron range removal efficiency is also 1 – 3 microns and higher.

Cake Washing: If the process requires washing to remove the API from the solids, then generally the pressure plate filter is a better alternative. If washing is not as critical, then the candle filter may be the optimum technology for clarification and recovery.

Heel Filtration: The remaining liquid in the vessel (liquid heel) can be removed from the candle filter or pressure plate filter by circulation, heel filters in the cone, or additional heel filter plates in the pressure plate filter.

Cake Drying: The candle filter can produce cakes with approximately 10% moisture. This moisture level depends upon the specific cake but the moisture lower limit is that moisture just above the cake cracking point. The pressure plate filter can produce bone dry cakes.



Cake Discharge: Both designs can easily discharge most cakes equally with no residual heel.

Clean-In-Place (CIP): Both units conduct CIP operations in identical manners by filling and circulating cleaning fluids while blowing gas in the reverse direction to the filtration direction, which creates a turbulent mixture or a quasi-ultrasonic cleaning effect. The pressure plate filter further enhances this operation with plate vibration.

TYPICAL TESTING TO DETERMINE THE OPTIMUM FILTRATION TECHNOLOGY OF VERTICAL CANDLE FILTER OR HORIZONTAL PLATE FILTER

Overview of Bench Top Testing in the BHS Laboratory

The BHS bench top testing is conducted using the BHS Pocket Leaf Filter, shown below. The testing will analyze cake depths, operating pressures, filter media, washing and drying efficiencies and cake discharge (qualitatively, based upon BHS experience).

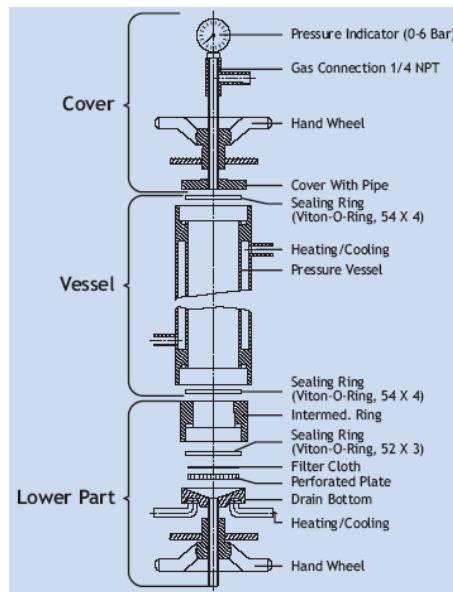

Figure 6: BHS Pocket Leaf Filter



Bench top tests are conducted on an API / Activated Carbon Slurry using a BHS-Filtration Pocket Leaf Filter. The tests are conducted to demonstrate that the activated carbon and impurities can be removed from the API by filtration. This test demonstrated that the API can be easily filtered, and that Thin-Cake pressure filtration using the BHS Candle Filter or BHS Pressure Plate Filter would provide excellent results for this application.

The following filtration options from BHS-Filtration are evaluated in this report and are suitable for this application: Candle Filter and Pressure Plate Filter

1. Test Purposes

The purposes of this test were to:

- 1.1 Determine if Activated Carbon and impurities could be separated from an API. The current filtration process is with cartridge filters:
 - A 12,000 liters batch of slurry is filtered in approximately 6 hours. This is an average rate of 50 liters/min.
 - The slurry contains activated carbon and impurities and is a dark black color. The filtrate is the product and should be a clear liquid.
 - The cake is washed and then discharged as a slurry for disposal.
- 1.2 Determine which type of thin-cake filtration is suitable for this process: Candle Filter or Pressure Plate Filter.
- 1.3 Determine the required size for the production equipment.

2. Test Methods

The BHS-Filtration Pocket Leaf Filter was used to gather data and make observations on this product. The following information was gathered during this test:

- 2.1 Filtrate Quality vs. Filter Media
- 1.2 Filtration Time vs. Feed Volume (Cake Height) and Filtration Pressure.
- 1.3 Cake Height vs. Feed Volume
- 1.4 Media Blinding vs. Number of Runs

3. Test Facilities

Tests were carried out in the BHS-Filtration laboratory with original slurry produced by the customer.

Test device: 400 ml Stainless Steel BHS-Pocket Leaf Filter with 12 cm² filter area
Filter cloths: Polypropylene
Temperature: Ambient Slurry
Ambient Pocket Leaf Filter
Ambient Nitrogen for pressurizing the filter and drying

4. Test Data – Confidential



5. Test Results

5.1 Filtrate Quality - The feed slurry is a dark black color and the filtrate should be a clear liquid. A polypropylene media produced clear filtrate that contained no visible solids.

5.2 Filtration Time

5.2.1 Filtration Time vs. Feed Volume

The filtration time increased with the square of the feed volume (cake height) as expected, shown in Figure 7. The data clearly demonstrate that the filtration time for smaller feed volumes (thin cakes) is the preferred filtration method.

The following equation can be used to predict the filtration time based on the data:

Equation 1: $t_F = a + b (V/A_F)^2$, where

t_F = the filtration time in minutes

a = a constant in minutes

b = a constant in minutes * m^4/m^6

V = the feed volume in m^3

A_F = the area of the filter in m^2

A least squares regression of the data yields the following constants for Runs 1, 2, 3, and 4:

	a	b	R2
Run 1, 15 psi	0.32 minutes	27.16 minutes * m^4/m^6	0.982
Run 2, 15 psi	0.89 minutes	69.53 minutes * m^4/m^6	0.975
Run 3, 30 psi	1.34 minutes	15.75 minutes * m^4/m^6	0.983
Run 4, 45 psi	1.72 minutes	9.67 minutes * m^4/m^6	0.992

5.2.2 Filtration Time vs. Pressure

The filtration time varied with the inverse of the filtration pressure, indicating that the cake is non-compressible, as shown in Figure 8. This means that pressure filtration will result in the highest filtration rates and the smallest filter area. The following equation can be used to predict the filtration time for a given amount of feed vs. the filtration pressure:

Equation 2: $t_F = a' + b'/P$, where

t_F = the filtration time in minutes

a' = a constant in minutes

b' = a constant in minutes*psi

P = the filtration pressure in psi

A least squares regression of the data yields the following constants for the filtration time for 350 ml of feed slurry:

	a'	b'	R2
Runs 2, 3, 4	-0.0315 minutes	96.092 minutes * psi	0.992

5.2.3 Cake Height vs. Feed Volume

The cake height was measured after each run and increased linearly with increasing feed volume. This indicates that the slurry was uniform from run to run, and also indicates the cake was not compressed during the filtration process. The following equation can be used to predict the cake height for a given amount of feed in a known filter area:

Equation 3: $h = a'' + b'' * (V/A_F)$, where

h = the cake height in mm

a'' = a constant in mm

b'' = a constant in $\text{mm} * \text{m}^2/\text{m}^3$

V = the feed volume in m^3

A_F = the area of the filter in m^2

5.3 Cloth Blinding

The same filter cloth was used for each trial and the time required for 400 ml of water to flow through the filter at 15 psi was recorded before the trials and after each run. The flow rate through the media slowed down after the first run, and then reached a steady rate. This indicates that a small and consistent amount of solids remains on the cloth after each run. This result is normal for a cloth media (unlike a cartridge filter that tends to blind over time due to the particles being trapped in the depth of the filter) and demonstrates that the cloth did not blind during these trials.

5.4 Cake Discharge

The cake was discharged dry prior to drying on Run 1, after 1 minute of drying on Run 2, and as a slurry on Runs 3 and 4. The cake discharge was excellent in each case. This allows the customer to choose the discharge method that is best for their particular situation.

Figure 7: Filtration Time Versus Feed Volume

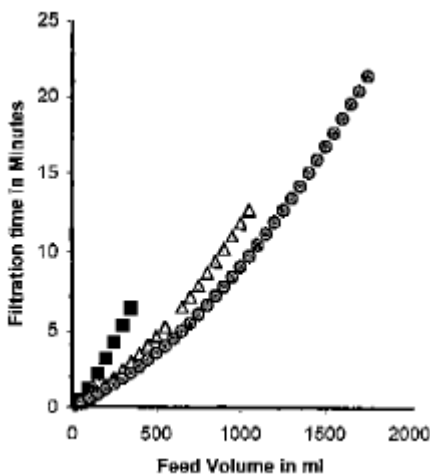
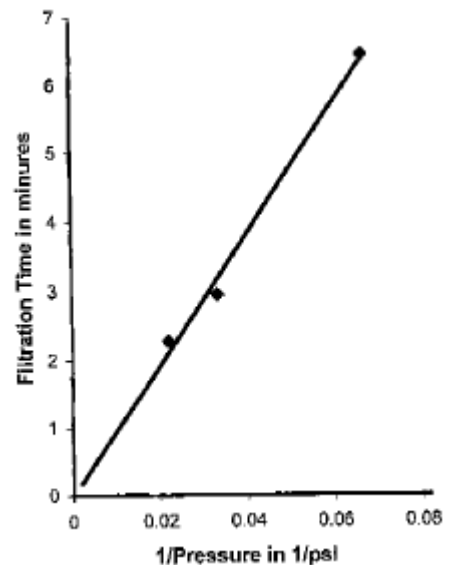

Figure 8: Filtration Time Versus 1/Pressure





6. Selection of Production Technologies and Scale-Up

The data indicates that Thin-Cake pressure filtration is the correct separation method for this product. BHS provides a complete range of filtration technologies and both a Candle Filter and a Pressure Plate Filter are suitable for this application. These filters are batch devices and the cycle time for a batch is the sum of the times for each step in the process.

The actual cycle time for a batch filter is the sum of:

t_{Fill}	=	Filling Time	= 5 minutes
$t_{Precoat}$	=	Precoat Time	= NA
$t_{Turbid\ Filtration}$	=	Turbid Filtration Time	= NA
t_F	=	Filtration Time	= See Each Case Below
t_W	=	Washing Time(s)	= 10 minutes
t_{Drain}	=	Draining Time	= NA
t_{Drying}	=	Drying Time	= NA
t_{Dis}	=	Discharge Time	= 5 minutes
t_{Total}	=	Total Cycle Time	= Filtration Time + 20 minutes

In order to provide the customer with the best possible solution for this process BHS-Filtration has evaluated the following two options for this application:

6.1 Option 1: Process The Entire Reactor Batch in One Drop with a BHS Candle Filter.

The cycle time should not exceed 6 hours (240 minutes), so the allowable filtration time if the entire batch is processed in one batch is 240 minutes – 20 minutes = 220 minutes. The Candle Filter operates with a typical cake thickness of 10 mm, and Equation 3 can be rearranged to determine the required filtration area to process a 12,000 liter batch.

$$A_F = b'' * V / (h - a'') = 12.846 \text{ mm} * \text{m}^2 / \text{m}^3 * 12 \text{ m}^3 / (10\text{mm} - 0.2436 \text{ mm}) = 15.8 \text{ m}^2$$

A Candle Filter Type KN 37/19 has an area of 18.8 m² and is the initial choice for this option. We now use Equation 1 and the data from Run 4 to confirm that the filtration time in this filter is acceptable:

$$t_F = a + b (V/A_F)^2 = 1.72 \text{ minutes} + 9.67 \text{ minutes} * \text{m}^4 / \text{m}^6 * (12 \text{ m}^3 / 18.8 \text{ m}^2)^2 = 5.7 \text{ minutes.}$$

This Filtration Time of 5.7 minutes is much less than the 220 minutes allowed, and this confirms that the Candle Filter Type KN 37/19 is large enough for Option 1. A smaller filter with multiple drops is also possible, but the cGMP requirement is for one complete batch for batch-to-batch integrity.



6.2 Option 2: Process The Entire Reactor Batch in One Drop with a BHS Pressure Plate Filter

For this application, the Pressure Plate Filter can operate with a cake thickness of 55 mm (maximum cake thickness = 65 mm) and Equation 3 can be rearranged to determine the required Filtration area to process a 12,000 liter batch.

$$A_F = b'' * V / (h - a'') = 12.846 \text{ mm} * \text{m}^2 / \text{m}^3 * 12 \text{ m}^3 / (55 \text{ mm} - 0.2436 \text{ mm}) = 2.82 \text{ m}^2$$

A Pressure Plate Filter Type TDF 760/80/7 has an area of 2.9 m² and is our initial choice for this option. We now use Equation 1 and the data from Run 4 to confirm that the filtration time in this filter is acceptable:

$$t_F = a + b (V/A_F)^2 = 1.72 \text{ minutes} + 9.67 \text{ minutes} * \text{m}^4 / \text{m}^6 * (12 \text{ m}^3 / 2.9 \text{ m}^2)^2 = 167 \text{ minutes.}$$

This Filtration Time of 167 minutes is less than the 220 minutes allowed, and this confirms that the Pressure Plate Filter Type TDF 760/80/7 is the correct size Pressure Plate Filter for Option 2.

TYPICAL CASE HISTORIES

Candle Filters

In a recent API installation, the customer installed two BHS candle filters for removing activated carbon and diatomaceous earth from a 3000 kg API. The details are as follows:

Installation: 2 x BHS KF 13 – 6 (13 candles with 6 m² of filter area)

Slurry has 25 kg of activated carbon + 15 kg of diatomaceous earth

Batch size is 3000 kg of an API

Filtration Pressure = 5 bar

Drying with nitrogen to 5% final moisture

Cycle Times:

20 minutes of turbid filtration

120 minutes of filtration for final production

20 minutes for draining, drying and cake discharge



TYPICAL CASE HISTORIES (Continued)

Candle Filters

In a similar installation for an API, the details are as follows:

KF 14-5 (5 m² with 14 candles)

De colorization of an API

- a. 8 Kg activated carbon + 7 Kg of diatomaceous earth
- b. 4000 liters of slurry
- c. Filtration = 30 minutes
- d. Drying = 5 minutes
- e. Discharge = 10 minutes

One product done in campaigns

The activated carbon and diatomaceous earth is easily filtered without precoat

11 batches / week @ 2 batches / day

Filter media sock: Polypropylene @ 14 microns

Operating Pressure: 2 – 6 bar

Cake Depth: 20 mm

Production results are identical to PLF tests of 1200 liters / m² / hour

Cake discharge is 100%; no residual heel

PTFE butterfly valve; no sealing problems; 350 mm valve with an 800 mm vessel diameter

Pressure Plate Filter

In this next application, a Pressure Plate Filter was chosen rather than a candle filter. The API is bound to the activated carbon so intense washing is required. The benefit of the vibrating plates allowed the solvent and carbon to mix in the vessel and then reset the bed by filtration. The horizontal plates provided for a well-defined cake structure for cake washing and then bone-dry cake discharge. The details are as follows:

Installation: TDF 1010-60-13 (13 plates with 10 m² of filter area)

Slurry has 80 – 100 kg of activated carbon + diatomaceous earth

Batch size is 5000 kg of an API

Filtration Pressure = 1 – 2 bar

Drying with nitrogen to 40% final moisture

Cycle Times:

4 minutes of turbid filtration

120 minutes of filtration for final production

20 minutes for draining, drying and cake discharge

TYPICAL INSTALLATIONS

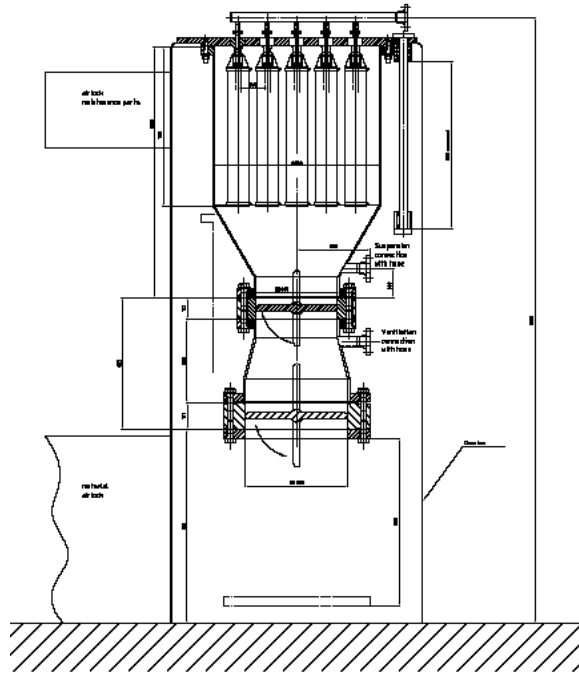

Figure 10: BHS Candle Filter with cGMP Candles installed in a Glove Box

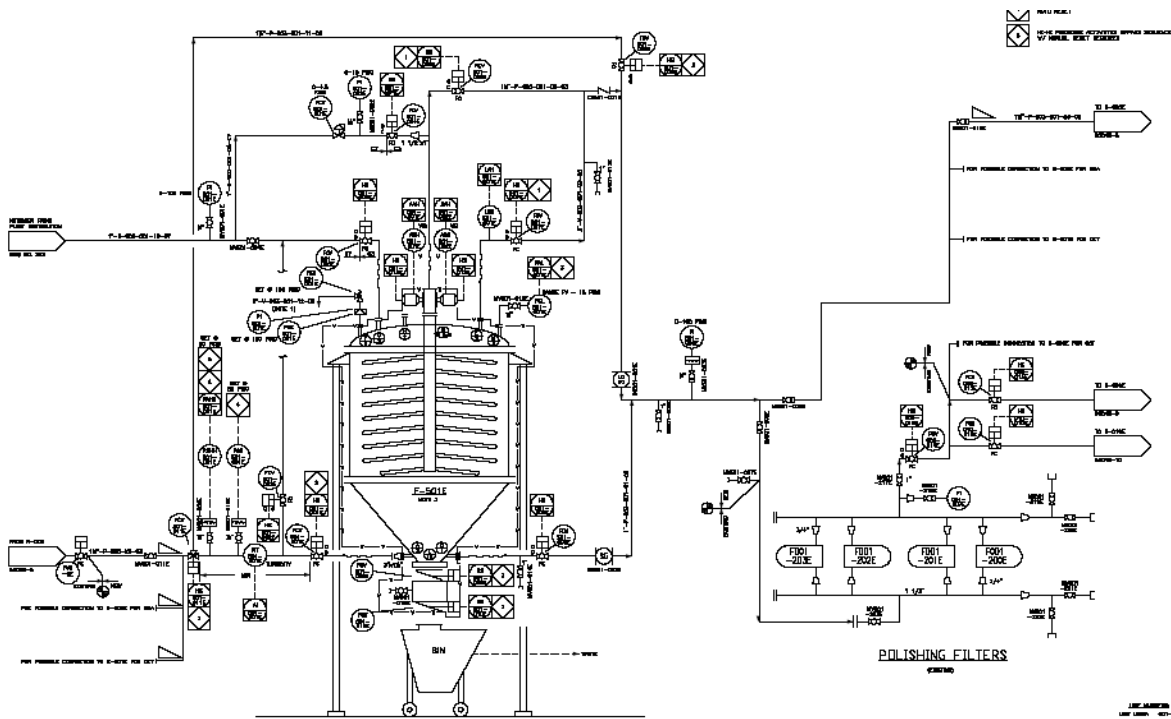

Figure 11: BHS Pressure Plate Filter for cGMP Production



PROCESS CONTROLS & TESTING

The final step of the process is controls and factory (FAT) and site acceptance (SAT) tests. The Batch-S88 standards allows for modular control system operation. It defines the process and cleaning operations in steps so that operators can perform certain tasks reliably and without variation to ensure a unit that is defined as clean. A typical sequence would be as follows:

- Idle – In Semi-Automatic/Automatic mode sequence is not running
- Running – Main Operation is running without any active sequences
 - Purging – Fast Purge Sequence Active
 - Setup – Setup Sequence Active
 - Filling – Filling Sequence Active
 - Wash 1 – Wash 1 Sequence Active
 - Wash 2 – Wash 2 Sequence Active
 - Blowing – Blow Sequence Active
 - Discharging – Discharge Sequence Active
 - Clean-In-Place
- Complete – Main Operation Sequence is complete
- Aborted – Sequence aborted.
- Holding – Holding Sequence Active
- Hold – Holding Sequence completed
- Restarting – Sequence is restarting from Hold state
- Grounding – Ground sequence is active

FAT and SAT tests are then performed using the S-88 standards and formats and repeating the procedures, as necessary. Finally, riboflavin tests, swab tests and other client specified tests can be conducted.

SUMMARY

Thin-cake filtration operations provide many benefits to the production / clarification process. By selecting the optimum thin-cake technology of candle filter or pressure plate filter, engineers can realize a more efficient process approach including solids handling and cleaning of equipment with minimal operator involvement for improved safety and environmental concerns.